



## Estrogen receptor pathways to AP-1

Peter J. Kushner<sup>a,\*</sup>, David A. Agard<sup>b</sup>, Geoffrey L. Greene<sup>d</sup>, Thomas S. Scanlan<sup>c</sup>,  
Andrew K. Shiau<sup>b</sup>, Rosalie M. Uht<sup>a</sup>, Paul Webb<sup>a</sup>

<sup>a</sup> Metabolic Research Unit, 1119 HSW, University of California, 3rd and Parnassus, San Francisco, CA 94143-0540, USA

<sup>b</sup> Department of Biochemistry, University of California, 3rd and Parnassus, San Francisco, CA 94143-0540, USA

<sup>c</sup> Department of Pharmacology, University of California, 3rd and Parnassus, San Francisco, CA 94143-0540, USA

<sup>d</sup> Ben May Institute, University of Chicago, Chicago, IL, USA

---

### Abstract

Estrogen receptor (ER) binds to estrogen response elements in target genes and recruits a coactivator complex of CBP-pl60 that mediates stimulation of transcription. ER also activates transcription at AP-1 sites that bind the Jun/Fos transcription factors, but not ER. We review the evidence regarding mechanisms whereby ER increases the activity of Jun/Fos and propose two pathways of ER action depending on the ER ( $\alpha$  or  $\beta$ ) and on the ligand. We propose that estrogen-ER $\alpha$  complexes use their activation functions (AF-1 and AF-2) to bind to the p 160 component of the coactivator complex recruited by Jun/Fos and trigger the coactivator to a higher state of activity. We propose that selective estrogen receptor modulator (SERM) complexes with ER $\beta$  and with truncated ER $\alpha$  derivatives use their DNA binding domain to titrate histone deacetylase (HDAC)-repressor complexes away from the Jun/Fos coactivator complex, thereby allowing unfettered activity of the coactivators. Finally, we consider the possible physiological significance of ER action at AP-1 sites. © 2000 Published by Elsevier Science Ltd.

*Keywords:* Estrogen receptor; Transcription factors; Coactivator

---

### 1. Introduction

The estrogen receptor (ER) activates transcription both from classical hormone response elements (EREs), to which the ER binds directly, and from various alternative response elements, to which the ER does not bind. ER action upon the ovalbumin proximal promoter and the collagenase and IGF-1 genes traces to AP-1 sites that bind members of the Jun/Fos family of transcription factors [1–11]. ER action upon the quinone reductase gene traces to an electrophile response element, and these have been reported to bind ATF transcription factors, which are potential dimerization partners with Jun [12]. ER action upon the cyclin D gene traces to a CRE-like element that also binds Jun/ATF [13,14]. ER also enhances the activity of promoters that are regulated by other factors. ER action at the E2F gene traces to a GC rich site and an adjacent CCAAAT site that bind SP1 and NF-Y, re-

spectively ([15] and references therein) and ER action at the Cathepsin D gene traces to a USF site [16]. Furthermore, ER action at the Myc, TGF beta 3, brain creatine kinase, EBBP and retinoic acid beta genes traces to discrete non-ERE sites whose binding proteins are not yet identified [17–21]. Thus, the ER has the potential to enhance the activities of a wide range of heterologous transcription factors.

While the relative significance of ER activation at heterologous response element is not yet clear, there are indications that such activation be as important as activation at EREs. Tamoxifen, a selective estrogen receptor modulator (SERM) that has been used extensively as an antiestrogen in breast cancer treatment, activates AP-1 target genes in uterine cells but not in breast tumor cells [6]. This cell specific effect parallels the effects of tamoxifen upon the growth of these cell types. Moreover, raloxifene, another SERM, lacks estrogen-like effects on AP-1 targets in uterine cells [9] and does not exert estrogen-like effects on cell proliferation. Extending the parallel, estrogen-liganded ER enhances AP-1 target genes in some breast cell lines but

---

\* Corresponding author. Tel.: +1 415 476 6790; fax: +1 415 476 1660.

E-mail address: kushner@itsa.ucsf.edu (P.J. Kushner).

represses AP-1 target genes in others, perhaps because of the specific composition of AP-1 proteins present in those cell lines (Jun/Fra-1 rather than Jun/Fos) [22]. Where ER stimulates transcription of AP-1 targets it stimulates proliferation, and where it represses AP-1 transcription it represses proliferation. Thus, ER action at AP-1 sites may reflect some of the mechanisms that ER uses to regulate genes that are involved in cellular growth response. Here, we review how ER works at classical response elements and our recent findings on ER action at AP-1 sites, and draw parallels between ER action at these two types of response element.

## 2. ER action at classical EREs

ER action at classical EREs is relatively well understood (Fig. 1). The ER first binds as a homodimer to specific estrogen response elements that are found within the promoters of target genes. The ER then uses two separate transactivation functions to bind coactivator proteins. AF-2, which lies within the ER-ligand binding domain (LBD), is the strongest transactivation function. It works by binding to short motifs (nuclear receptor boxes, NR boxes, consensus LXXLL) that are found repeated three or four times within the p160s. AF-2/p160 contacts are estrogen dependent and SERMs (such as tamoxifen and raloxifene) completely block these AF-2/p160 contacts. AF-1, which lies within the ER aminoterminal domain (NTD), generally shows very little independent activity, and serves only to synergize with AF-2. It works by binding to the C-terminus of p160 coactivators such as GRIP1 [23]. After growth factor stimulation, and the subsequent NTD phosphorylation at serine 118, there is also a further interaction with p68 RNA helicase [24–26]. Both the p160s, and the p68 RNA helicase, are components of a large coactivator complex that also includes the integrator molecule, CBP/p300. Thus, ER action at

### ER activates at EREs by recruiting coactivators

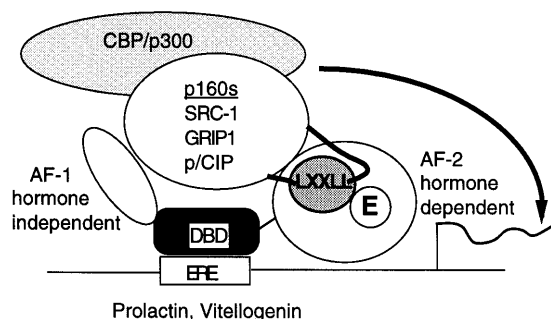

Fig. 1. ER acts at an ERE by binding both DNA and coactivators.

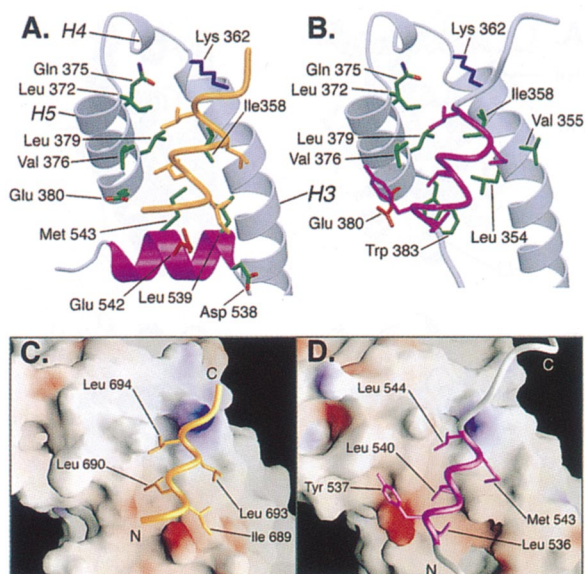

Fig. 2. Atomic structures of ER bound to the agonist DES and the NR box2 of GRIP1 (A and C) and of ER bound to tamoxifen (B and D). Top panels: the hydrophobic cleft of the ER depicted as a purple ribbon, with the coactivator in gold (A) or helix 12 in dark purple (B); bottom panels: the same views with the ER depicted as a surface.

classical EREs may be compared to that of a molecular tether, with the DBD bound to EREs and AF-1 and AF-2 bound to p160s, which serves as the ER contact point within a large coactivator complex.

Our recent structural studies have provided satisfying explanations for AF-2/p160 interactions and for the ability of tamoxifen to block the ligand dependent AF-2 activity (Fig. 2). Using the crystal structures of the ER-LBD and the closely related thyroid receptor LBD as a guide [27,28], we systematically mutated residues that were exposed upon the LBD surface and asked whether they were required for AF-2 activity. We found that key AF-2 residues mapped to a small hydrophobic cleft comprised of helices 3,4,5 and 12, and mutations within the cleft diminished both AF-2 function and p160 binding in parallel [28–30]. Subsequently, we obtained cocrystals of the ER bound to the agonist DES and a GRIP1 NR box2 peptide. This structure revealed that the NR box forms a two-turn amphipathic helix, with the three NR box leucines projecting down into the hydrophobic cleft on the surface of the receptor. Key AF-2 residues either directly contact the NR box leucines or form a charge clamp that stabilizes formation of the NR box amphipathic helix [28]. Crystal structures of the ER bound to either tamoxifen, or raloxifene reveal that the SERMs prevent p160 binding by displacing helix 12 and rotating it 110 degrees so that it sits within the hydrophobic cleft, thereby occluding the p160 binding cleft [28,31]. Remarkably, helix 12 recognizes the hydrophobic cleft through a sequence that mimics the NR

box, LXXML, with the helix 12 leucines and methionine almost superimposable with the three leucines of the NR box. Thus, our understanding of classical estrogen response now reaches to the atomic level and sets the criterion for understanding of ER action at alternative response elements.

### 3. How does ER work at AP-1 sites? – Two distinct pathways to AP-1

The fundamental facts of ER action at AP-1 have been confirmed by several labs. First, binding of Jun and Fos to the AP-1 site is needed for ER action, and ER appears to increase the intrinsic transcriptional activity of Jun/Fos when bound to the site [1,3,6,11,22,32]. Second, tamoxifen, and other SERMs are able to activate AP-1 target genes. The stimulation of AP-1 targets by SERMs is especially evident with ER $\beta$ . For example, with raloxifene ER $\beta$  is 10-fold more efficient in activating AP-1 targets than ER $\alpha$  with estrogen. A complete description of ER action at AP-1 sites must therefore answer two questions. How does ER $\alpha$  act at AP-1 sites, since it cannot bind to the DNA of those sites. Moreover, how can SERMs allow ER $\beta$  to activate AP-1 targets so efficiently?

Our first clues to the mechanism of ER action at AP-1 sites were suggested by the genetic dissection of ER $\alpha$  domains that are needed for activation of AP-1 targets. These explorations showed that the activation functions of ER $\alpha$ , AF-1 and AF-2, are needed for action at AP-1 in the presence of estrogen [11]. Indeed, the isolated LBD is a strong estrogen-dependent activator of AP-1 target genes, and this activation requires the integrity of AF-2 functions (Fig. 3A). In the context of full length ER $\alpha$  mutations in AF-1 also severely compromise estrogen activation of AP-1. These observations suggest that the ER $\alpha$ -estrogen complex stimulates AP-1 by using the AF-1 and AF-2 surfaces.

As mentioned above ER $\beta$  is a potent activator at AP-1 in the presence of SERMs. This action is completely independent of the AF-2 function of ER $\beta$  [11]. Since ER $\beta$ , unlike ER $\alpha$ , has no constitutive AF-1 function [11,23,33–36], this suggests that SERM-ER $\beta$  complexes activate AP-1 by an AF-independent pathway. Indeed, the absence of an ER $\beta$  AF-1 led us to test the behavior of ER $\alpha$  derivatives that had deletions of AF-1. Shockingly, ER $\alpha$  truncations of AF-1, like ER $\beta$ , efficiently activate AP-1 targets with SERMs (Fig. 3B). Moreover, ER $\alpha$  $\Delta$ AF-1 does not show the restricted cell specificity of full length ER $\alpha$ , it allowed potent SERM activation at AP-1 sites in a wide range of cell types. The ligand preference for AP-1 activation by ER $\alpha$  $\Delta$ AF-1 perfectly mimicked the preference of ER $\beta$ . As for ER $\beta$ , ICI 182,780, and raloxifene were most potent followed by tamoxifen. Estrogen and DES have almost

no effect. Thus, both ER $\beta$  and ER $\alpha$  derivatives have an efficient pathway to AP-1 activation in the presence of SERMs that is AF independent.

To explain these findings we suggested that ERs can enhance AP-1 activity through two entirely separate mechanisms (Fig. 3C). As proposed in Fig. 4, ER $\alpha$  enhances AP-1 responsive transcription in a manner that requires ER transactivation functions, but not the ER-DBD. This pathway is activated by estrogens (and perhaps by tamoxifen in conditions in which AF-1 activity is high), but not by raloxifene or ICI. Second, ER $\beta$  and AF-1 deleted ER $\alpha$  enhance AP-1 responsive transcription in a manner that is independent of ER activation functions, but does require the ER-DBD.

#### The isolated ER LBD is active at AP-1

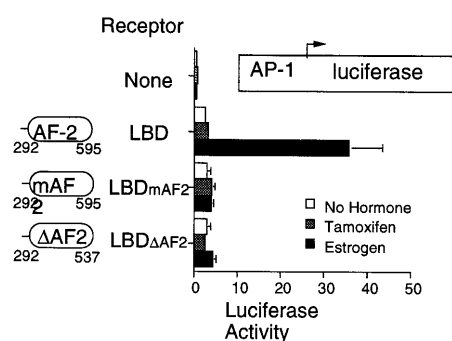

#### ERbeta efficiently activates AP-1 with SERMs.

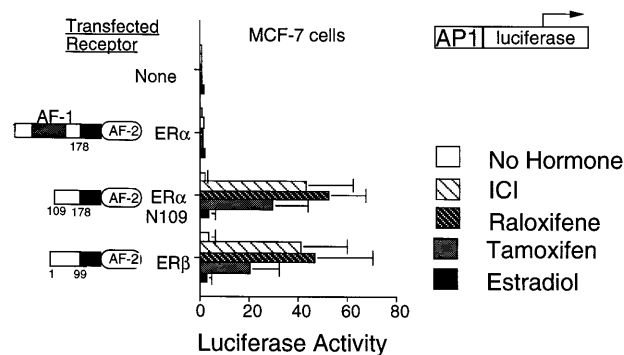

#### ER contact surfaces in GRIP1 mediate receptor action at AP-1

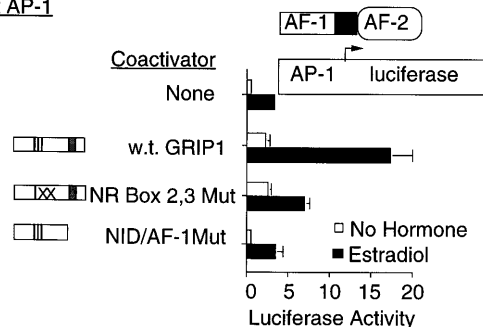

Fig. 3. (A) Isolated ER AF-2 activates at AP-1. (B) ER $\beta$  and AF-1 deleted ER $\alpha$  are potent activators with SERMs at AP-1. (C) The NR boxes and Nid AF-1 of p160s participate in estrogen-ER action at AP-1.

### ER Activation at AP-1 Sites: Two Pathways

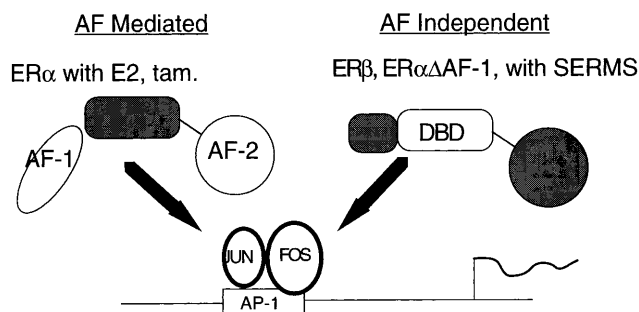

Fig. 4. ERs use two separate pathways to AP-1. ER $\alpha$  with estrogen or with tamoxifen activate AP-1 through an AF mediated pathway. ER $\beta$  and AF-1 deleted ER $\alpha$  potentially activate AP-1 through an AF independent pathway in the presence of the SERMs, raloxifene and ICI 182,780.

This AF-1 independent pathway is activated by SERMs, especially those with high antiestrogenic potential (ICI 182,780, raloxifene).

#### 4. Mechanisms of the ER action at AP-1 sites

What can we say about the molecular mechanisms of the two pathways of ER action at AP-1 sites? For convenience, we will deal with the AF mediated and AF independent pathways separately.

##### 4.1. The AF dependent pathway – ER interactions with coactivators at the AP-1 site

The mutational analysis of estrogen-ER action at AP-1 sites points to a role for ER-p160 contact in the activation. Moreover, mammalian one hybrid assays, in which a Herpes Virus VP16 activation function was fused to either full length ER, or an ER devoid of its DBD, revealed that the VP16 activation function strongly potentiated estrogen responses at AP-1 sites [6]. This observation suggests that the estrogen-liganded ER is present within the complex of proteins at the AP-1 regulated promoter. We do not believe that the ER is held at the promoter by contacts with Jun/Fos because the LBD does not bind to these proteins, yet can activate AP-1. Instead, we propose another point of contact. The Jun/Fos heterodimer stimulates transcription by recruiting CBP/p300 and associated proteins [37]. These associated proteins may include p160 coactivators since these are known to both bind CBP in vivo and to potentiate AP-1 activity when elevated (see Fig. 5A). Thus, the very same coactivator complex of CBP and p160 that is recruited by ER at an ERE is recruited by Jun/Fos at an AP-1 site. The contacts with the coactivator complex are different, however. Jun/Fos contact the CBP component, whereas ER contacts pri-

marily the p160 component. This means that the ER binding contacts are still accessible when the complex has been recruited to Jun/Fos. ER could thus join the pre-existing Jun/Fos/Coactivator complex at the promoter via contacts with p160s. We thus propose that ER binds to p160s that have been recruited by Jun/Fos and in doing so “triggers” the coactivators into a higher state of activity (Fig. 5A). Considering the relationship of the coactivators to ER at the ERE (Fig. 1) and the AP-1 site (Fig. 5A) this might be called the “flip horizontal” model because it can be made by hitting the “flip horizontal” key on one’s favorite drawing program.

Whereas the triggering model is abstract in that no mechanism of triggering is yet specified, it does make some striking predictions. The ability of ER to activate at AP-1 should be independent of Jun/Fos themselves, which are only serving to recruit the coactivators that are the true target of ER. We tested this prediction with a fusion of CBP to yeast GAL4 DBD, which was directly tethered to the promoter, thus obviating the need for Jun/Fos. The free ER or free ER LBD, neither of which can bind to the promoter, are each able to trigger tethered CBP into full activity in the presence of estrogen (P. Webb and P.J. Kushner, in preparation). Thus, ER can itself serve the function of the coactivator when the coactivator is directly tethered to DNA! Our explorations of the mechanisms of ER action at teth-

##### ER-estrogen activates at alternative response elements by triggering coactivators

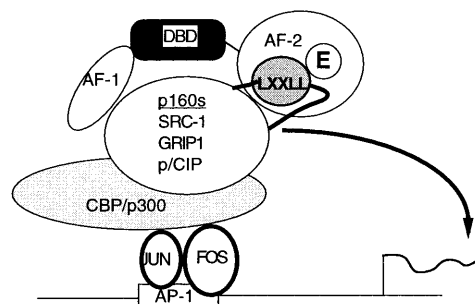

##### ER-tamoxifen triggers the activity of coactivators that are recruited to complex promoters by other factors

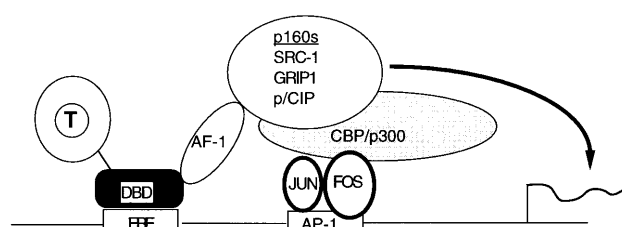

Fig. 5. (A) Model of estrogen-ER $\alpha$  activation of AP-1. Jun/Fos recruit CBP-p160s, and ER binds to the coactivators and triggers them to higher activity. (B) Potential role of triggering at complex promoters. Heterologous transcription factors recruit coactivators and the ER triggers the coactivators through AF-1.

ered CBP reveal that, in many ways, it is similar to ER action at AP-1 sites. Thus ER utilized AF-1 and AF-2 to enhance CBP activity, just as it utilizes the AF functions to activate AP-1. A second prediction of the triggering model is that p160s should be required for triggering. The surfaces that contact ER AF-1 and ER AF-2, the Nid-AF-1 and the NR boxes, should also be required. Indeed, in accordance with this prediction, elevation of GRIP1 potentiated estrogen action at AP-1 sites, and this effect required the cognate AF-1 and AF-2 binding sites upon GRIP1 (Nid-AT-1 and NR boxes) (Fig. 3C).

We think that the triggering model has the potential to explain the long-standing observation that ER AF-1 has promoter specific activity. The general observation has been that AF-1 is quite weak on promoters with only a simple TATA box and ERE, but can be much stronger on complex promoters with binding sites for other transcription factors. Examples are the C3 complement promoter and PS2 promoters, in which the estrogen response is spread through cooperating elements that bind ER and other proteins. We propose that ER AF-1 has too little affinity to p160s to recruit them to simple promoters, and hence shows little independent activity at a simple promoter. With a complex promoter, the non-ER transcription factors pre-recruit CBP-p160 coactivators and thereby relieve ER of the job. The ER AF-1, while weak in recruiting, is strong in triggering (P. Webb and P.J. Kushner, in preparation) and can now trigger the coactivator complex that has been recruited by the other transcription factors (Fig. 5B). Thus, triggering may be an important component of ER action at both alternate and classical response elements, and may explain some of the estrogen-like effects of tamoxifen, which allows strong AF-1 triggering.

#### 4.2. The AF independent pathway – titration of repressors from the AP-1 regulated promoter?

The AF independent pathway is completely different from the AF dependent pathway. First, it does not rely on ER transactivation functions. In fact, ER activation functions strongly suppress the AF independent pathway, indicating that the two pathways must show at least some degree of mutual exclusivity. Second, unlike the estrogen-liganded ER, the SERM-liganded ER seemed to activate AP-1 responsive transcription without even directly participating in the AP-1 complex!

If the SERM-ER is not present within the AP-1 transcription complex then how can it activate AP-1 responsive transcription? The first explanation that we considered centered upon recent observations, which indicated that estrogens initiate MAP kinase cascades in some cell types. We therefore wondered whether the

#### ER-SERM induction of AP-1 by diversion of HDACs

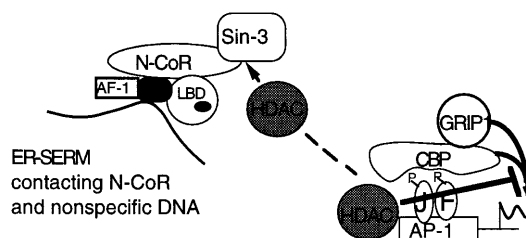

Fig. 6. Model of ER-SERM action at AP-1 by titration of repressors. ER-SERM located away from the AP-1 site (for example, on non-specific DNA) binds a complex of N-CoR and HDACs through the DBD-hinge-LBD. This draws away HDACs that are associated with the AP-1 site and allows unopposed activity of HATs in coactivators recruited by Jun/Fos.

SERMs might initiate second messenger cascades that would result in AP-1 activation. Despite the appeal of this explanation, we found that SERMs (and estrogens) failed to activate MAP or JNK kinases in our experimental conditions, even when these ligands strongly activated AP-1 responsive transcription.

The explanation we instead favor is shown in Fig. 6. It exploits the recent and striking finding that ER can bind corepressors such as N-CoR, but only in the presence of SERMs [38,39]. We propose that the SERM-ER complex at some site away from the AP-1 promoter, such as non-specific DNA, bind N-CoR and similar corepressors. The SERM-ER-N-CoR complex then binds other repressor components such as histone deacetylases (HDACs). The net effect of this binding is to sequester HDACs away from promoters regulated by AP-1 site. This allows histone acetylases (HATs) in the coactivator complex that has been recruited by Jun/Fos free to act without opposition of HDACs. Notice that this model would, if correct, explain why SERM effects at AP-1 sites are independent of ER transactivation functions. SERM ER AP-1 pathways require ER/corepressor binding surfaces, not ER/coactivator surfaces. The model would also explain how ER could enhance AP-1 activity without participating in the AP-1 transcription complex, it would work by pulling repressors away from the complex and by definition, must be away from the complex to function.

This model makes some specific predictions that we are beginning to test. HDAC inhibitors should induce AP-1 regulated promoters and block further induction by SERM-ER combinations. Preliminary results suggest that this prediction is fulfilled (R. Uht and P.J. Kushner, in preparation). The model also predicts that mutations that disrupt the hypothetical interface between ER and the corepressor complex should block the ability of SERMs to activate at AP-1. We have several candidates for such mutations including a potent point mutation in the DNA binding domain,

K206A. We believe that the K206A ER is deficient in binding a component of the putative HDAC repression complex. Whereas we do not as yet have direct biochemical evidence for a specific deficiency, we have indirect evidence for such a deficiency using the repressor titration assay developed by Milan Bagchi and his colleagues (Uht et al., in preparation). In this assay, the transcriptional activity of the progesterone receptor (PR) liganded to the partial agonist RU486 is potentiated by the presence of ER-antiestrogen or by unliganded thyroid hormone receptor (TR). The K206A ER (and a similar mutation in TR) is unable to potentiate PR in this repressor titration assay (Uht et al.). Amazingly, the K206A mutant is completely deficient in AP-1 activation with tamoxifen, raloxifene, or ICI 182,780. The K206A mutant bound to estrogen, in contrast, is a very potent activator of AP-1, often 10 to 100 times as potent as the wild type ER. We interpret this as indicating that the mutation blocks interaction with a critical component of the corepressor complex. This prevents the mutant from titrating HDACs when bound to SERMs. Conversely, the mutation prevents HDACs from accompanying the estrogen-ER when engaged in triggering and thus allows for super-normal activation.

#### 4.2.1. Physiology of ER action at AP-1 sites

We have presented evidence that ER action at AP-1 sites is mediated by two pathways and that these pathways involve ER interactions with coactivators and corepressors. The reader may wonder about an obvious implication of this model. In neither case is a key interaction between ER and the Jun/Fos proteins needed. Could ER interactions with such relatively general cellular components really be responsible for specific ER regulation of genes with alternate response elements *in vivo*? We believe so. Many of the diverse ER regulated transcription factors that we detailed in the Section 1 (Jun/Fos, ATF, NF-Y, etc.) work by binding CBP, the target molecule for triggering. We suspect that the coactivator and corepressor complexes that are associated with certain genes could be specifically “poised” for ER action, perhaps by differences in their composition or modification state. To confirm that ER action at alternate response elements is an important component of ER action *in vivo*, we are currently generating transgenic mice that express mutant ERs which superactivate at AP-1 sites, but are relatively unaffected in their ability to mount a classical response. If ER action at AP-1 sites is indeed, an important physiological process, then the mutant ERs should enhance the estrogen responses in ER target tissues, if ER action at AP-1 sites is unimportant then we could see nothing. We expect results from such animals shortly.

## References

- [1] M.P. Gaub, M. Bellard, I. Scheuer, P. Chambon, C.P. Sassone, Activation of the ovalbumin gene by the estrogen receptor involves the fos-jun complex, *Cell* 63 (1990) 1267–1276.
- [2] L. Tora, M.P. Gaub, S. Mader, A. Dierich, M. Bellard, P. Chambon, Cell-specific activity of a GGTCA half-palindromic oestrogen-responsive element in the chicken ovalbumin gene promoter, *EMBO J.* 7 (1988) 3771–3778.
- [3] A. Philips, D. Chalbos, H. Rochefort, Estradiol increases and anti-estrogens antagonize the growth factor-induced activator protein-1 activity in MCF7 breast cancer cells without affecting c-fos and c-jun synthesis, *J. Biol. Chem.* 268 (1993) 14103–14108.
- [4] Y. Umayahara, R. Kawamori, H. Watada, E. Imano, N. Iwama, T. Morishima, Y. Yamasaki, Y. Kajimoto, T. Kamada, Estrogen regulation of the insulin-like growth factor I gene transcription involves an AP-1 enhancer, *J. Biol. Chem.* 269 (1994) 16433–16442.
- [5] M. Tzukerman, X.K. Zhang, M. Pfahl, Inhibition of estrogen receptor activity by the tumor promoter 12-O-tetradecanoylphorbol-13-acetate: a molecular analysis, *Mol. Endocrinol.* 5 (1991) 1983–1992.
- [6] P. Webb, G.N. Lopez, R.M. Uht, P.J. Kushner, Tamoxifen activation of the estrogen receptor/AP-1 pathway: potential origin for the cell-specific estrogen-like effects of antiestrogens, *Mol. Endocrinol.* 9 (1995) 443–456.
- [7] F. Saatcioglu, G. Lopez, B.L. West, E. Zandi, W. Feng, H. Lu, A. Esmaili, J.W. Apriletti, P.J. Kushner, J.D. Baxter, M. Karin, Mutations in the conserved C-terminal sequence in thyroid hormone receptor dissociate hormone-dependent activation from interference with AP-1 activity, *Mol. Cell Biol.* 17 (1997) 4687–4695.
- [8] H. Rochefort, Oestrogen- and anti-oestrogen-regulated genes in human breast cancer, *Ciba. Found. Symp.* 191 (1995) 254–265 Discussion 265–268.
- [9] K. Paech, P. Webb, G.G. Kuiper, S. Nilsson, J. Gustafsson, P.J. Kushner, T.S. Scanlan, Differential ligand activation of estrogen receptors ERalpha and ERbeta at AP1 sites, *Science* 277 (1997) 1508–1510.
- [10] R.M. Uht, C.M. Anderson, P. Webb, P.J. Kushner, Transcriptional activities of estrogen and glucocorticoid receptors are functionally integrated at the AP-1 response element, *Endocrinology* 138 (1997) 2900–2908.
- [11] P. Webb, P. Nguyen, C. Valentine, G. Lopez, et al., The estrogen receptor enhances AP-1 activity by two distinct mechanisms with different requirements for receptor transactivation functions, *Mol. Endocrinol.* 13 (1999) 1672–1685.
- [12] M.M. Montano, B.S. Katzenellenbogen, The quinone reductase gene: a unique estrogen receptor-regulated gene that is activated by antiestrogens, *Proc Natl Acad Sci USA* 94 (1997) 2581–2586.
- [13] D. Geum, W. Sun, S.K. Paik, C.C. Lee, K. Kim, Estrogen-induced cyclin D1 and D3 gene expressions during mouse uterine cell proliferation *in vivo*: differential induction mechanism of cyclin D1 and D3, *Mol. Reprod. Devel.* 46 (1997) 450–458.
- [14] L. Altucci, R. Addeo, L. Cicatiello, S. Dauvois, M.G. Parker, M. Truss, M. Beato, V. Sica, F. Bresciani, A. Weisz, 17beta-Estradiol induces cyclin D1 gene transcription, p36D1-p34cdk4 complex activation and p105Rb phosphorylation during mitogenic stimulation of G(1)-arrested human breast cancer cells, *Oncogene* 12 (1996) 2315–2324.
- [15] W. Wang, L. Dong, B. Saville, S. Safe, Transcriptional activation of E2F1 gene expression by 17beta-estradiol in MCF-7 cells is regulated by NFY-Sp1/estrogen receptor interactions, *Mol. Endocrinol.* 13 (1999) 1373–1387.

- [16] W. Xing, T.K. Archer, Upstream stimulatory factors mediate estrogen receptor activation of the cathepsin D promoter, *Mol. Endocrinol.* 12 (1998) 1310–1321.
- [17] D. Dubik, R.P. Shiu, Mechanism of estrogen activation of c-myc oncogene expression, *Oncogene* 7 (1992) 1587–1594.
- [18] N. Yang, M. Venugopalan, S. Hardikar, A. Glasebrook, Identification of an estrogen response element activated by metabolites of 17-beta-estradiol and raloxifene, *Science* 273 (1996) 1222–1225.
- [19] D.A. Sukovich, R. Mukherjee, P.A. Benfield, A novel, cell-type-specific mechanism for estrogen receptor-mediated gene activation in the absence of an estrogen-responsive element, *Mol. Cell Biol.* 14 (1994) 7134–7143.
- [20] H.L. Liu, E. Golder-Novoselsky, M.H. Seto, L. Webster, J. McClary, D.A. Zajchowski, The novel estrogen-responsive B-box protein (EBBP) gene is tamoxifen-regulated in cells expressing an estrogen receptor DNA-binding domain mutant, *Mol. Endocrinol.* 12 (1998) 1733–1748.
- [21] M.G. Elgort, A. Zou, K.B. Marschke, E.A. Allegretto, Estrogen and estrogen receptor antagonists stimulate transcription from the human retinoic acid receptor-alpha 1 promoter via a novel sequence, *Mol. Endocrinol.* 10 (1996) 477–487.
- [22] A. Philips, C. Teyssier, F. Galtier, C. Rivier-Covas, J.M. Rey, H. Rochefort, D. Chalbos, FRA-1 expression level modulates regulation of activator protein-1 activity by estradiol in breast cancer cells, *Mol. Endocrinol.* 12 (1998) 973–985.
- [23] P. Webb, P. Nguyen, J. Shinsako, C.M. Anderson, M.P. Nguyen, E. McKinerney, B.S. Katzenellenbogen, M. Stallcup, P.J. Kushner, Estrogen receptor activation function 1 works by binding p160 coactivator proteins, *Mol. Endocrinol.* 12 (1998) 1605–1618.
- [24] S. Kato, H. Endoh, Y. Masuhiro, T. Kitamoto, S. Uchiyama, H. Sasaki, S. Masushige, Y. Gotoh, E. Nishida, H. Kawashima, et al., Activation of the estrogen receptor through phosphorylation by mitogen-activated protein kinase, *Science* 270 (1995) 1491–1494.
- [25] G. Bunone, P.A. Briand, R.J. Miksicek, D. Picard, Activation of the unliganded estrogen receptor by EGF involves the MAP kinase pathway and direct phosphorylation, *EMBO J.* 15 (1996) 2174–2183.
- [26] H. Endoh, K. Maruyama, Y. Masuhiro, Y. Kobayashi, M. Goto, H. Tai, J. Yanagisawa, D. Metzger, S. Hashimoto, S. Kato, Purification and identification of p68 RNA helicase acting as a transcriptional coactivator specific for the activation function 1 of human estrogen receptor alpha, *Mol. Cell Biol.* 19 (1999) 5363–5372.
- [27] R.L. Wagner, J.W. Apriletti, M.E. McGrath, B.L. West, J.D. Baxter, R.J. Fletterick, A structural role for hormone in the thyroid hormone receptor, *Nature* 378 (1995) 690–697.
- [28] A.K. Shiau, D. Barstad, P.M. Loria, L. Cheng, P.J. Kushner, D.A. Agard, G.L. Greene, The structural basis of estrogen receptor/coactivator recognition and the antagonism of this interaction by tamoxifen, *Cell* 95 (1998) 927–937.
- [29] W. Feng, R.C. Ribeiro, R.L. Wagner, H. Nguyen, J.W. Apriletti, R.J. Fletterick, J.D. Baxter, P.J. Kushner, B.L. West, Hormone-dependent coactivator binding to a hydrophobic cleft on nuclear receptors, *Science* 280 (1998) 1747–1749.
- [30] H.Y. Mak, S. Hoare, P.M. Henttu, M.G. Parker, Molecular determinants of the estrogen receptor-coactivator interface, *Mol. Cell Biol.* 19 (1999) 3895–3903.
- [31] A.M. Brzozowski, A.C. Pike, Z. Dauter, R.E. Hubbard, T. Bonn, O. Engstrom, L. Ohman, G.L. Greene, J.A. Gustafsson, M. Carlquist, Molecular basis of agonism and antagonism in the oestrogen receptor, *Nature* 389 (1997) 753–758.
- [32] P. Webb, M.-R. Keneally, J. Shinsako, R. Uht, C. Anderson, K. Paech, T.S. Scanlan, P.J. Kushner, The ER/API pathway: a window on the cell-specific estrogen-like effects of antiestrogens, in: H. Gronemeyer, U. Fuhrmann, K. Parczyk (Eds.), *Molecular Basis of Sex Hormone Receptor Function*, Springer, Berlin, 1998, pp. 121–140.
- [33] G.B. Tremblay, A. Tremblay, N.G. Copeland, D.J. Gilbert, N.A. Jenkins, F. Labrie, V. Giguere, Cloning, chromosomal localization, and functional analysis of the murine estrogen receptor beta, *Mol. Endocrinol.* 11 (1997) 353–365.
- [34] A. Tremblay, G.B. Tremblay, F. Labrie, V. Giguere, Ligand-independent recruitment of SRC-1 to estrogen receptor beta through phosphorylation of activation function AF-1, *Mol. Cell.* 3 (1999) 513–519.
- [35] J.M. Hall, D.P. McDonnell, The estrogen receptor beta-isoform (ERbeta) of the human estrogen receptor modulates ER alpha transcriptional activity and is a key regulator of the cellular response to estrogens and antiestrogens, *Endocrinology* 140 (1999) 5566–5578.
- [36] E.M. McNerney, K.E. Weis, J. Sun, S. Mosselman, B.S. Katzenellenbogen, Transcription activation by the human estrogen receptor subtype beta (ER beta) studied with ER beta and ER alpha receptor chimeras, *Endocrinology* 139 (1998) 4513–4522.
- [37] P.S. Goldman, V.K. Tran, R.H. Goodman, The multifunctional role of the co-activator CBP in transcriptional regulation, *Recent Prog Horm Res* 52 (1997) 103–119 Discussion 119–120.
- [38] T.A. Jackson, J.K. Richer, D.L. Bain, G.S. Takimoto, L. Tung, K.B. Horwitz, The partial agonist activity of antagonist-occupied steroid receptors is controlled by a novel hinge domain-binding coactivator L7/SPA and the corepressors N-CoR or SMRT, *Mol. Endocrinol.* 11 (1997) 693–705.
- [39] R.M. Lavinsky, K. Jepsen, T. Heinzel, J. Torchia, T.M. Mullen, R. Schiff, R.A. Del, M. Ricote, S. Ngo, J. Gemsch, S.G. Hilsenbeck, C.K. Osborne, C.K. Glass, M.G. Rosenfeld, D.W. Rose, Diverse signaling pathways modulate nuclear receptor recruitment of N-CoR and SMRT complexes, *Proc Natl Acad Sci USA* 95 (1998) 2920–2925.